



Product: Commander Oil Filter Adapter Kit

Disclaimer: Check with your dealer if you have any questions on how this will affect any warranty before installation. Will require more oil once installed than manual states.

Instructions:

- **Note:** Best time to install this kit is when your machine needs an oil change. Drain all oils then install the kit.
- Lift up your bed to gain access to where the filter adapter will be mounted and hoses will be run.
 - It may be easier to do installation with the bed in the full tip position with the mounting pin removed to give you more room to work.
- On the passenger side of the frame near the Air Filter housing there is a existing threaded insert installed from the factory that will be used for mounting. Behind that remove the clip that hold the vent line in place.

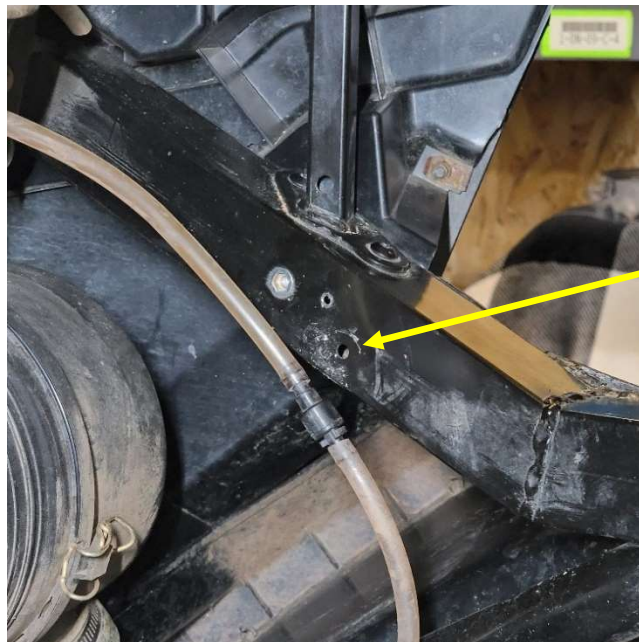

Thank you for your purchase.

For a list of more products we offer please visit marqcadeng.com or message us on facebook at marqCAD Engineering if you don't see what you are looking for on the website.

- Install the filter housing on the inside of the frame by securing with the bolt and washer supplied. Bolt and washer will go through the slotted hole to the threaded insert on the frame hand tight. Pull the filter housing up to seat the bracket tab against the frame and install supplied self-tapping screw in the smaller hole in filter housing bracket.

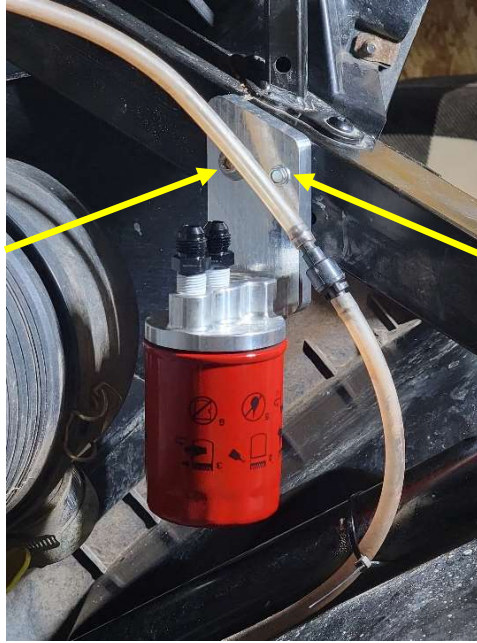

- To gain access to the stock oil filter you will have to remove the access cover on the passenger side of the motor by removing the 3 screws that hold it on.

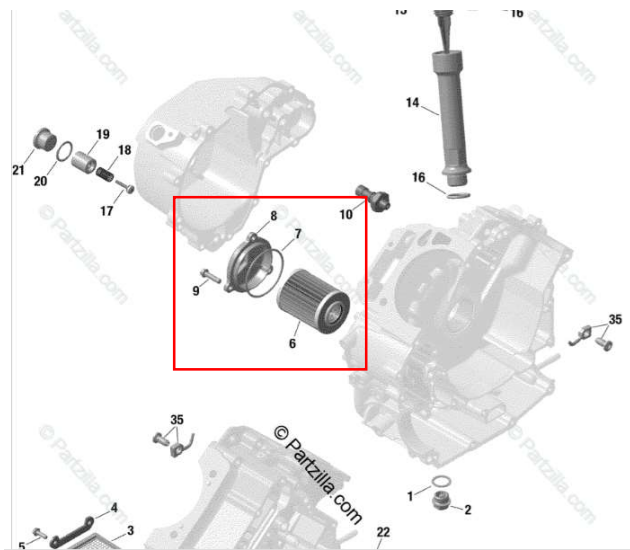

Thank you for your purchase.

For a list of more products we offer please visit marqcadeng.com or message us on facebook at marqCAD Engineering if you don't see what you are looking for on the website.

- Remove the stock oil filter cover and filter. Remove the gasket from the stock oil filter and install it onto the end of the engine side adapter as shown below. Be sure the supplied o-ring is installed on the engine side adapter as well.



- Install the engine side adapter with the 3 bolts that were used for the OEM filter cover.
- Install the hose fittings to the oil filter mounted to the frame finger tight to start. The hoses and lines will be marked with red and yellow paint marker. Red marked fittings should go together and yellow fittings should go together.



Thank you for your purchase.

For a list of more products we offer please visit marqcadeng.com or message us on facebook at marqCAD Engineering if you don't see what you are looking for on the website.

- Feed the lines around the top of the air box, around along the firewall, and down to the engine filter adapter. Be sure that the lines are not bent to tight causing and line kinks. Be sure that the lines are not ran to close to the exhaust manifold or the front driveshaft.



- Install the lines to the motor side adapter the same way as the filter adapter. Red fittings together and yellow fittings together. Tighten all 4 of the hose fittings to the adapters.
- Install the hose separator clamps along the hoses to keep them from rubbing together. This will help keep them together while feeding the lines down to the motor and help keep them from rubbing against each other.



Thank you for your purchase.

For a list of more products we offer please visit marqcadeng.com or message us on facebook at marqCAD Engineering if you don't see what you are looking for on the website.

- Secure the vent line to the oil lines with the supplied zip tie.



- Add the recommended amount of oil to start as if you were doing a normal oil change. Run the machine for 15-30 seconds, turn machine off, and then check the oil level and add the necessary amount so oil level is correct on the dip stick.
- Run the machine again for awhile to heat up the system and check for any leaks.
- Secure the oil lines using the supplied zip ties as you see fit along the firewall.

Thank you for your purchase.

For a list of more products we offer please visit marqcadeng.com or message us on facebook at marqCAD Engineering if you don't see what you are looking for on the website.